



Manual & Safety Instruction

***PLEASE READ CAREFULLY BEFORE OPERATEING THE WINCH**

Content

Electric Winch Usage	3
Safety Warnings & Precautions	3
2.1 Danger.....	3
2.2 Moving Parts Entanglement Hazard.....	5
2.3 General Safety.....	5
2.4 Installation Safety.....	6
2.5 Avoid Winch and Equipment Damage.....	7
2.6 General Tips for Safe Operation.....	8
3. Electric Winch Installation	8
3.1 Unpack Your Winch.....	8
3.2 Mount Your Winch.....	9
3.3 Fix Your Winch.....	9
3.4 Install Your Winch Fairlead.....	9
3.5 Install Control Box.....	10
3.6 Connect Electric Cables.....	10
Test Your Winch.....	11
Practice Using.....	11
4. Electric Winch Operation	12
4.1 Step 1: Disengage Clutch.....	12
Step 2: Pull Rope to Anchor Point.....	13
Step 3: Engage Clutch.....	13
Step 4: Winching.....	13
Step 5: For Vehicle Recovery.....	13
4.6 Step 6: Disconnect Remote Control.....	14
4.7 Winch Accessories You May Need During Winching.....	15
4.8 Some Tips for Better Winching.....	15
5. Electric Winch Maintenance & Storage	17
5.1 General Inspection.....	17
6 Troubleshooting Guide.....	19
7. Technical specifications	21

1. Electric Winch Usage

Electric winches are extensively used for trucks, 4x4 cars, farm cars, UTV, ATV, go-cart and other vehicles. It can work in extreme environment for vehicle recovery, like in the sands, swamp, snow, muddy road and so on. So it is named “the fifth wheel”. For example, the car was stuck in mire, but it can't go out by itself. Like this case, we can pull the car out by electric winch. In other situations, we also can use electric winch to pass the barrier, pull the goods etc. Electric winch is a self-protection and recovery necessary device for firefighting, military, police, immigration, hydrology and other off-road activities.

2. Safety Warnings & Precautions

2.1 Danger



1. Vehicle batteries contain gasses that are inflammable and can explode violently.

Dress properly

- Do not wear loose clothing or jewelry. They can be caught in moving parts.
- Non-skid footwear is recommended.
- Protective hair covering to contain long hair.

Battery

- Be sure that battery is in good condition. Avoid contact with battery acid or other contaminants.
- Always wear eye protection when working around a battery.
- Always follow wiring diagrams
- Have the engine running when using the winch, to avoid flattening the battery.





2. Improper wiring can result in electrical shock or explosion.

- Always insulate and protect all exposed wiring and electrical terminals.
- Always place supplied terminal boots on wires and terminals as directed by installation instructions.
- Never connect DC Powered winches to AC current.
- Never operate a DC winch in an explosive environment.
- Never route electrical cables across sharp edges; near parts that get hot, nor through or around moving parts.
- Always verify area is clear of fuel lines, fuel tank, brake lines, electrical wires, etc., when drilling.
- Always consult operator's manual for proper wiring details.



3. Improper use or overloading of the winch can result in a release of load or rope failure.

Before winching a load, be sure the clutch is fully in the engaged position.

- **Always** properly seat load in throat of hook.
- **Always** use a shackle or strap when attaching the hook to an anchor point.
- **Always** use a hook with a latch and insure hook latch is closed and not supporting load.
- **Always** keep hands clear of rope, hook loop, hook and fairlead opening during installation, operation and when spooling in or out.
- **Always** use supplied hook strap whenever spooling rope in or out during installation and operation.
- **Never** touch rope or hook while in tension or under load.
- **Never** hook the rope back onto itself.
- **Never** use winch to lift or move persons.

- **Never** use winch as a hoist or to suspend a load.



2.2 Moving Parts Entanglement Hazard

- Keep the duration of your pulls as short as possible.
- Do not step over a cable, or near a cable under load.
- **Never** engage or disengage clutch if winch is under load, rope is in tension or drum is moving.
- **Always** keep hands clear of rope, hook loop, hook and fairlead opening during installation, operation and when spooling in or out.
- **Always** keep wired remote control lead clear of the drum, rope and rigging. Inspect for cracks, pinches, frayed wires or loose connections. Replace remote control if damaged. **Use only manufacturer's identical replacements with the exact specifications.**
- **Always** pass wired remote control through a window to avoid pinching lead in door, when using remote inside a vehicle.
- **Never** leave remote control where it can be activated during free spooling, rigging, or when the winch is not being used.
- If the motor becomes uncomfortably hot to the touch, stop and let it cool for a few minutes. Do not pull more than one minute at or near the rated load. Do not maintain power to the winch if the motor stalls.
- Check motor often, never winching out of max pull and specific time, it will make the motor so hot and damaged.

2.3 General Safety



- **Always** know your winch. Take time to fully read the Installation Guide and the Basic Guide to

Winching Techniques in order to understand your winch and its operation.

- Electric winches are for intermittent usage and should not be used in constant duty applications.
- Modification, alteration, or deviation to the winch should only be made by qualified Winch Company. (Altering or modifying the winch (i.e. machining or welding) in any way, will void the warranty.)
- **Never** operate this winch if you are under 16 years of age.

- **Never** operate this winch when under the influence of drugs, alcohol or medication.
- **Never** exceed winch or rope capacity listed on product data sheet. Double line using a snatch block to reduce winch load.
- Always be aware of stability of vehicle and load during winching, keep others away. Alert all bystanders of an unstable condition.
- Keep a **safe distance**, proper footing and balance all the time.



2.4 Installation Safety

- **Always** inspect rope, hook, and slings before operating winch. Frayed, kinked or damaged rope must be replaced immediately. Damaged components must be replaced before operation. If a cable pulls loose or breaks under load it can lash back and cause serious personal injury or death.



(Figure 2-4)

- **Always** pre-stretch wire rope and re-spool under load before use. Tightly wound wire rope reduces chances of “binding”, which can damage the rope.
- **Always** spool the rope onto the drum in the direction specified by the winch warning label on the winch and/or documentation. This is required for the automatic brake (if so equipped) to function properly.
- **Always** choose a mounting location that is sufficiently strong to withstand the maximum pulling capacity of your winch.
- **Always** use factory approved mounting hardware, components, and accessories.
- **Always** use grade 5 (grade 8.8 metric) or better mounting hardware.
- **Never** weld mounting bolts.
- **Always** use carefully when using longer bolts than those supplied from factory. Bolts that are too long can damage the base and/or prevent the winch from being mounted securely.

- **Always** mount the winch and attach the hook to the rope's end loop before connecting the electrical wiring.
- **Always** position fairlead with WARNING label on top.
- **Never** obscure warning and instruction labels. Slowly take up the wire rope slack until taut.
- **Never** leave remote control plugged into winch when free spooling, rigging, or when the winch is not being used.
- **Never** hook rope back onto itself. In this case it causes rope to be damaged.
- **Always** use a choker chain, choker rope, or tree trunk protector on the anchor.
- **Always** be certain that the anchor you select will withstand the load and the strap or chain will not slip.
- **Always** select an anchor point as far away as possible. This will provide the winch with its greatest pulling power.
- **Never** operate a winch with less than 5 turns of wire rope around the drum and operate a winch with less than 8 turns of synthetic rope around the winch drum. The rope could come loose from the drum.
- **Never** expose the rope to heat sources or chemicals.
- **Never** pull the rope around non-rotating sheaves or rollers.
- **Never** allow rope to tangle or jam while winching. Rope could break before winch stalls.
- **Never** knot or tie the rope to secure a load or repair a broken rope.
- **Never** use a hook whose throat opening has increased, or whose tip is bent or twisted.
- **Never** use to raise, suspend, lower or secure horizontally hinged doors or ramps without additional counter balance springs centrifugal locking devices, or other secondary means of supporting the moving ramp or door.
- **Always** store the remote control in a protected, clean, dry area.
- **Always** double line or pick distant anchor point when rigging. This maximizes pulling power and avoids overloading the winch.
- Take recovery blanket on wire rope if possible before operating winch, it will make vehicle and operator safe once wire rope damaged.



2.5 Avoid Winch and Equipment Damage

- **Always** avoid side pulls which can pile up rope at one end of the drum. This can damage rope or winch.
- Do **not** operate the winch at extreme angles. Do not exceed the specified angles for a roller fairlead. For a hawse fairlead, the angle should be as close to straight as possible.
- **Never** use winch to tow other vehicles or objects. Shock loads can momentarily exceed capacity of rope and winch.
- **Always** avoid “powering out” for extended distances. This causes excess heat and wear on the winch motor and brake.
- **Always** use care to not damage the vehicle frame when anchoring to a vehicle during a winching operation.
- **Never** “jog” rope under load. Shock loads can momentarily exceed capacity of rope and winch.
- **Never** use winch to secure a load during transport.
- **Never** submerge winch in water.
- **Always** store the remote control in a protected, clean, dry area.

NOTICE

2.6 GENERAL TIPS FOR SAFE OPERATION

1. To prevent battery drain and maximize power and speed of the winch, the vehicle engine should be kept running during operation. If the winch is used for a considerable time with the engine off, the battery may drain and be too weak to restart the engine.
2. Inspect the winch installation, check bolts to ensure that all bolts are tightened before each operation.
3. Any winch that appears to be damaged in any way, is found to be worn, or operates abnormally SHALL BE REMOVED FROM SERVICE UNTIL REPAIRED. It is recommended that the necessary repairs be made by a manufacturer’s authorized repair facility.
4. The wire rope may break before the motor stalls, for heavy loads at or near rated capacity, use a pulley block/snake block to reduce the load on the wire rope.
5. Do not move the vehicle to pull a load (Towing) on the winch cable, this could result cable breakage.

3. Electric Winch Installation

3.1 Unpack Your Winch

Unpack your new winch and ensure that all the parts are included by referring to parts list and exploded view drawings provided in this manual. If you find any parts missing or broken, please contact store where you purchase

from as soon as possible.

3.2 Mount Your Winch

Choose a suitable location to mount the winch that is strong enough to withstand the loads (A mounting plate is recommended for winch installation). Check your mounting plate or bumper has the suitable screw holes, if not drill four mounting holes according to the bolt pattern mentioned in the winch specifications

3.3 Fix Your Winch

Install your winch on the mounting plate or bumper, refer to the screws and make sure to screw them tight. Be sure the motor, drum and gear box on the one surface after installation.

3.4 Install Your Winch Fairlead

Fix the fairlead on the mounting plate or bumper, all the winch fairleads come predrilled. If you use any other mounting platforms, drill two holes for the fairlead installation. Position the holes such that the fairlead opening hole stretches from the circumference of the drum to the end of the maximum permissible layers on the drum in the direction cable is being.

Note the winch direction after installation, the rope runs through the bottom of the drum.

3.5 Install Control Box

(Figure 3-5)

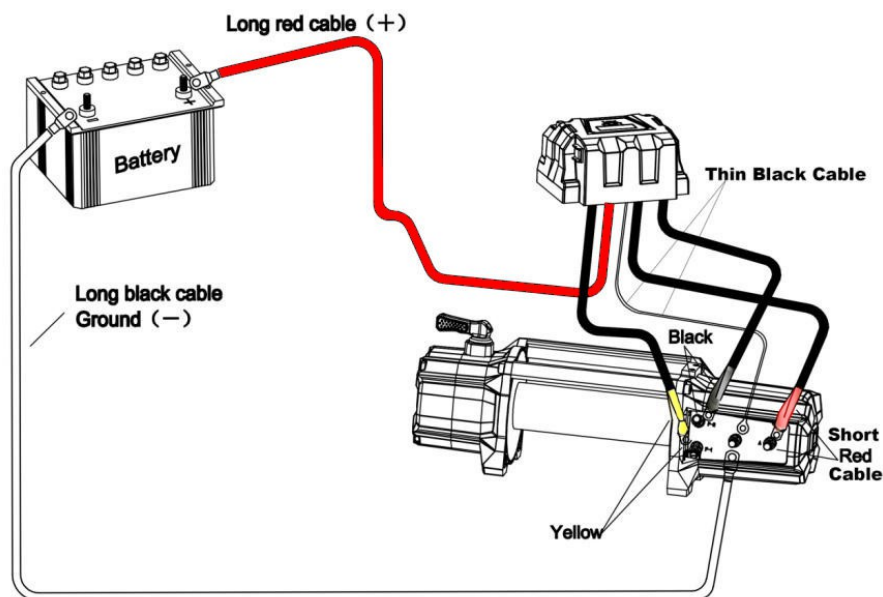

- Short red cable connects to the red terminal (A) of the motor.
- Short black cable with yellow jacket connects to the yellow terminal of the motor.
- Short black cable with black jacket connects to the black terminal of the motor.
- Thin black cable connects to bottom terminal of the motor.
- Long black cable connects to bottom terminal of the motor.

3.6 Connect Electric Cables

- **Long Red** cable connects to the **Positive (+)** of battery.
- **Long Black** cable connects to the **Negative (-)** of battery.

Connecting ATV series winch to the external relay unit:

- Wired and wireless remote control (optional) are connected to the relay unit.
- The unit included 2 pcs short electric wires(1 red and 1 black) and 2 pcs long electric wires. 2 pcs short electric wires are connect the relay to motor. 2 pcs long electric wires are connect the relay to the battery power.

Connecting ATV series winch to control box(optional):

- There are 2 short electric wires (1 red and 1 black) and 2 pcs long electric wires
On the control box.
- Connect the red short wires to the **Positive (+)**of motor.
- Connect the black short wires to the **Negative (-)**of motor.
- **Long Red** cable connects to the **Positive (+)** of battery.
- **Long Black** cable connects to the **Negative (-)** of battery.

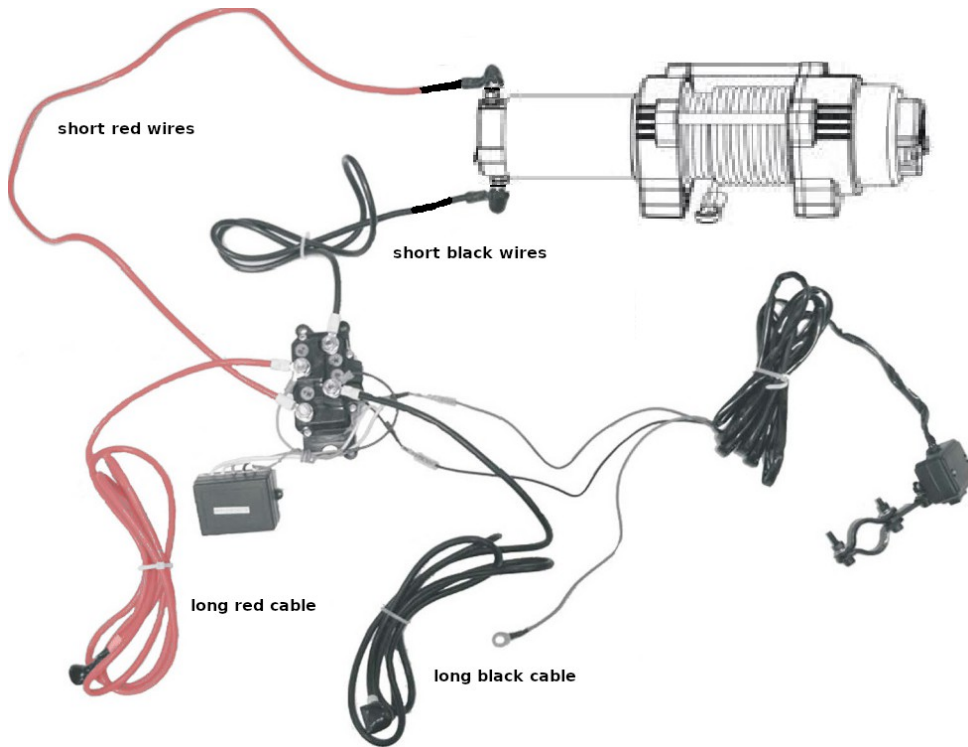
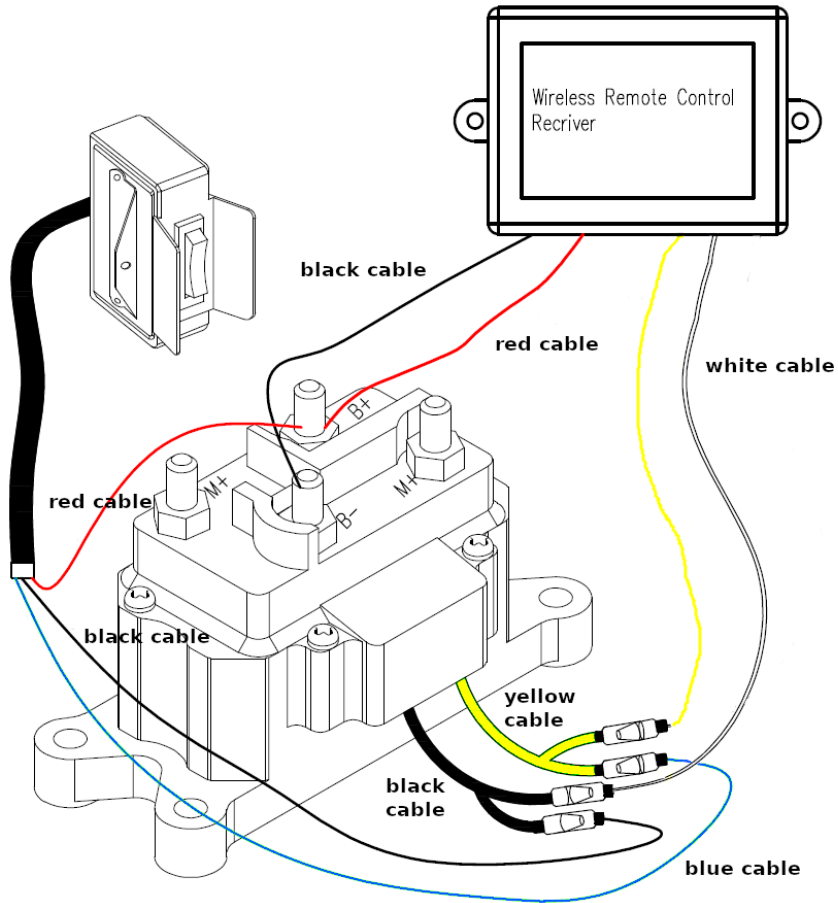

3.7 Test Your Winch

After proper installation and connection, place the clutch in the “Disengaged” position, pull out the winch rope for about 2 meters, then turn the clutch to the “Engaged” position, and handle the remote control to see if the winch works. If the winch doesn’t work, please check if all the things are in proper condition, such as, if the cable connection is correct and tight or the vehicle battery is sufficient. If the winch still does not work after thorough check, please contact the supplier.

3.8 Practice Using

After winch has been installed, take some time and practice using it so you will be familiar with all operation. Periodically check winch installation to ensure that all bolts are tight.

4. Electric Winch Operation

NOTE: For optimal winch performance, **Winch** recommends that use a fully charged 12V battery with at least 650 CCA. Further it is advised to keep the engine running during the winch operation, so that the battery is being charged continuously.

All winches are equipped with a clutch lever that engages/disengages the clutch. Clutch when engaged, winch can pull rope in; Clutch when disengaged, winch can pull rope out.

CAUTION: When using your **Winch**, always has at least 5 turns of wire rope or at least 8 turns of synthetic rope on the drum before winching; Ensure the clutch is fully engaged or fully disengaged to avoid any injuries and damages.

CAUTION: All Winches are for intermittent use only. Wait until the motor cool down before resuming operation.

Potential causes of motor damage:

1. Long-duration pulls.
2. Low battery.
3. Overloading winch pulling capacity.
4. If there is a large rock right in front of your axle, frame, or skid plate, you can winch horizontally and the only thing you'll accomplish is bending something, or burning out your winch motor.

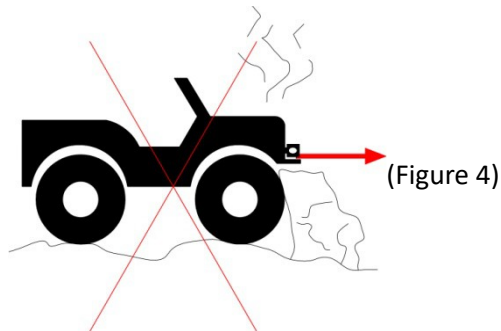

4.1 Step1: Disengage Clutch

Disengage your winch by rotating the clutch to **FREE-SPOOL** position or lift your clutch and turn to **FREE-SPOOL** position.

4.2 Step 2: Pull Rope to Anchor Point

Pull out enough rope to reach your anchor point. Be sure to keep ascertain amount of tension in the wire. It can become twisted and over wrap when slackened, leading to rope damage. To prevent loosing the end, hold the winch hook in the hook strap while you work.

4.3 Step 3: Engage Clutch

Engage your winch by sliding the clutch to **ENGAGED** position or lift your clutch and turn to **ENGAGED** position.

NOTICE

If necessary, pull the rope out slightly until the clutch is seated correctly.

4.4 Step 4: Winching

Connect handle remote control to control box, keep distance from winch and rope for safety, press button on handle remote control to IN for winching, if you use wireless remote, please press IN button to winching.(Figure 4-4)

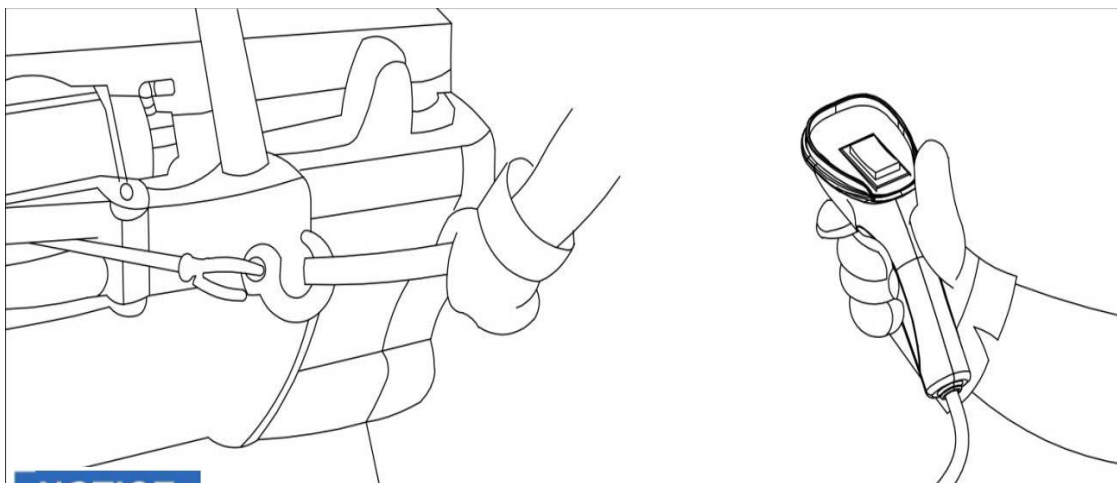

Always disconnect the remote control when not in use.

4.5 Step 5: For Vehicle Recovery

Continue pulling until the vehicle is on stable ground. If you are able to drive the vehicle, the winching operation is complete. Once recovery of the vehicle is complete, be sure to secure the vehicle's brakes and put the Transmission in "park". Release tension in the rope.

Disconnect rope from the anchor, and then rewind rope. The person handling the rope should walk the rope inland not let it slide through the hand and control the winch at all times.

4.6 Step6: Disconnect Remote Control

Disconnect the remote control cord and store in a clean and dry place. Winching operations are now complete. Put the cap on the socket.

WARNING

- **Always** be aware of stability of vehicle and load during winching, keep others away. Alert all bystanders of an

unstable condition.

- **Always** keep a **safe distance**, proper footing and balance all the time.
- **Always** disconnect the cable to the vehicle battery after winching.

NOTICE

All above connections is only for winch and winch parts. Any damage or injure caused by any other winch part is out of warranty and duty.

Attention:

1. Be sure cables are not drawn taught across any surface, which could possibly damage them.
2. Connect battery and screw the nut on the all terminals to avoid any connection loose.
3. Operate the wire remote controller after installation to make winch work in both directions.
4. Never hook the rope back onto itself. This could damage the rope. A tree saver is recommended.

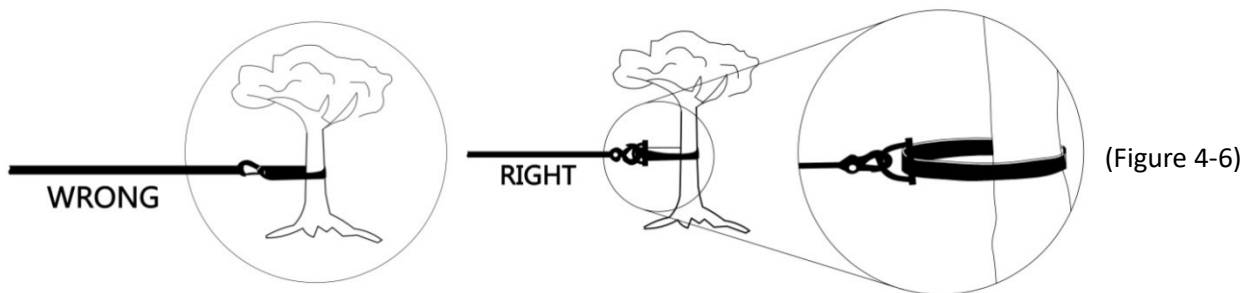

5. Never allow rope to tangle or jam while winching. Rope could break before winch stalls.
6. Never exceed winch or rope capacity listed on product data sheet. Double line using a snatch block to reduce winch load.
7. Do not reverse the operation immediately. Relay can be easily damaged in this way.
8. Avoid continuous pulls from extreme angles. This can cause the wire rope to bunch at one end of the drum resulting in damage to the wire rope or winch. Do not exceed the specified angles for a roller fairlead. For a hawse fairlead, the angle should be as close to straight as possible.

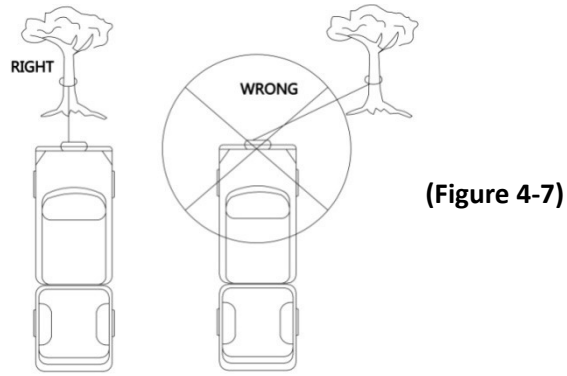

4.7 Winch Accessories You May Need During Winching

In order to be prepared for all recovery scenarios it is recommended to be equipped with a full recovery kit. These kits can include but are not limited to:

1. Winch Mounting Plate
2. Farm Jack
3. Receiver
4. Shackle
5. Square Hook
6. Heavy duty chain
7. Tree Saver
8. Recovery Blanket
9. Snatch Block
10. Gloves

4.8 Some Tips for Better Winching

1. The use of a snatch block

(1) Double Line

The use of a snatch block will aid recovery operations by providing a doubling of the winch capacity and a halving of the winching speed, and the means to maintain a direct line pull to the center of the rollers. When double loading during stationary winching, the winch hook should be attached to the chassis of the vehicle.

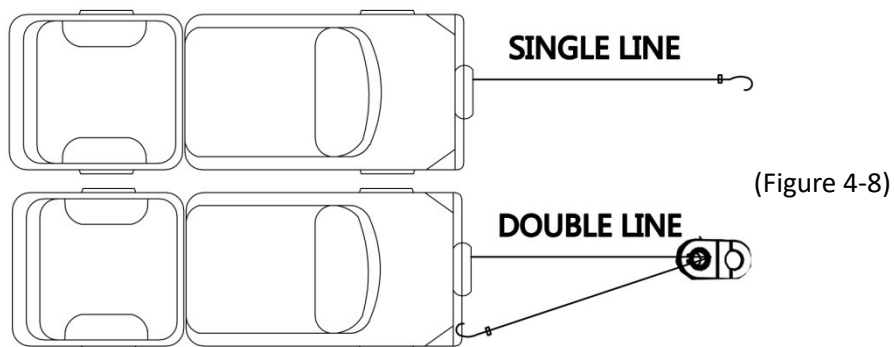

- (2) Change the Pulling Direction

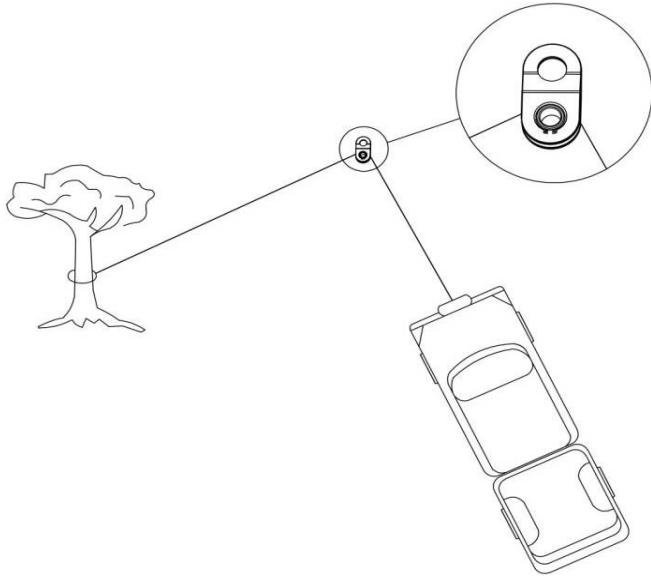

(Figure 4-9)

(3) Increasing pulling power & duration

For loads over 1/2 rated capacity, use a pulley block to double line the rope. This will reduce the load on the winch and up to 50% of the strain on the rope. Attach to the frame or other load bearing part.

2. Ground Anchor

Pull out winch rope and fix to the anchor point, the anchor point should be a ground anchor, a tree strong enough, a vehicle being recovered (Figure 2-4).

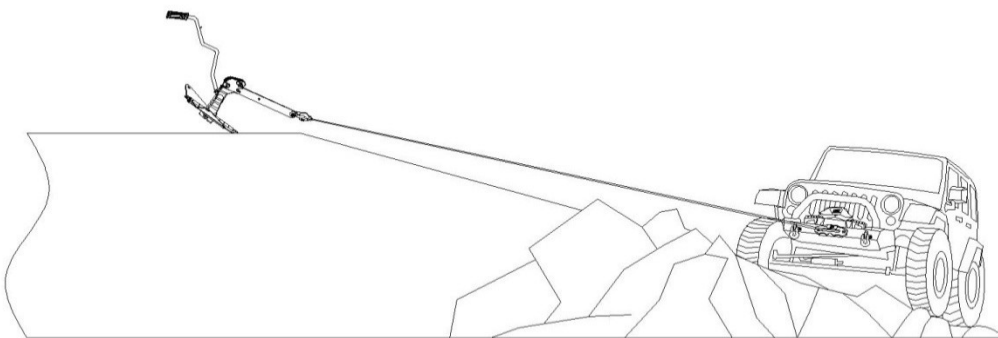

(Figure 4-10)

3. Recovery blanket or other heavy duty material

The quickest and easiest way to pull the rope out from the drum is to freespool it with the clutch in the disengaged position. When pulling, put a damper, blanket or other heavy duty material over the rope near the

hook end, if the rope fail for any reason, there will be barrier to help the rope from whipping and causing injury.
(Figure 3-4)

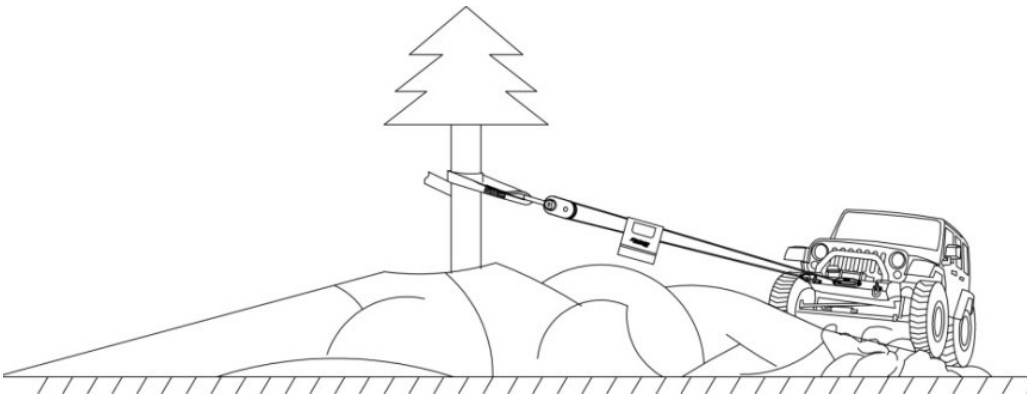

(Figure 4-11)

5. Electric Winch Maintenance & Storage

5.1 General Inspection

- 1) The gear box has been lubricated and is sealed at the factory. No further internal lubrication is required for the life of the winch. The winch should not immersion in water (waterproof winch should not be soaked in water for a long time). If the winch immersions in water by accident, you should loose the earth screw, put the net water as soon as possible. And you should use the winch within 3 days, make the motor to work and not stop until hands can feel it hot, as it can rid of water vapor into the motor.
- 2) Do not attempt to disassemble the gear box. Repairs should be done by an authorized repair center.
- 3) Lubricate the cable periodically using light penetrating oil. Please replace a new cable as soon as possible if it occurs glitch, fractures, and creases.
- 4) Periodically check the tightness of the mounting bolts and electrical connections. Remove all dirt or corrosion and always keep clean. (Check battery cables and electrical connections at 90 day intervals to be certain they are clean and tight at all connection points.)
- 5) You should clean and lubricate after using; also should store the winch in the dry and cool place, disengage the clutch, and avoid children to contact and play.
- 6) If ach assembly or connection screw is loose or corrode, please repair and replace it timely.
- 7) Check monthly the action of the clutch, making sure it is fully engaging and disengaging. If clutch is not fully engaging, inspect clutch shifter assembly parts, check for damage or excessive wear and replace as necessary. Corrosion on electrical connections will reduce performance or may cause a short. Clean all connections

especially in the remote control switch and receptacle. In salty environments use a silicone sealer to protect from corrosion.

To minimize corrosion of the internal motor components that may occur due to condensation, power the winch in or out periodically. Energizing the motor will generate heat, which will help dissipate any moisture buildup in the motor. This should be performed at periodic intervals (such as with each oil change to your vehicle). Note: Refer to the Troubleshooting Guide if the motor has been submerged.

6. Troubleshooting Guide

Trouble Shooting

SYMPTOM	POSSIBLE CAUSE	SUGGESTED REMEDY
Motor does not turn on	Defective switch Assy	Replace switch Assy
	Switch assemble not connected properly	Insert switch Assy firmly to the connector
	Loss battery cable	Tighten nuts on cable connectors
	Solenoid malfunctioning	Tap solenoid to free contact, applying 12 volts to coil terminal directly. Make an audible clicking when activating
	Defective motor	Check for voltage at armature port with switch pressed. If voltage is present, replace motor.
Motor runs too hot	Long period of operation	Let winch cool down periodically
	Insufficient battery	Check battery terminal voltage under load. If 10 volts or less, replace or parallel another battery to it.
Motor runs slowly or without normal power	Battery runs down	Recharge battery by running vehicle's engine
	Insufficient current or voltage	Clean, tighten or replace the connector
	Bad connection	Check battery cable for corrosion. Clean and grease.
Motor runs but cable drum does not turn	Clutch not engaged	Ensure lever is completely in "Engaged" position
Winch runs in one direction only	Defective or stuck solenoid	Tap solenoid to free contacts. Repair or replace solenoid.
	Defective switch Assy	Replace switch Assy
Motor water damage	Disconnect from battery	Remove ground bolt on bottom of motor and drain.
	Submerged in water or water from high pressure car wash	Allow to drain and dry thoroughly, then run motor without a load in short bursts to dry windings.
Will not hold load	Excessive load	Reduce load or double line
	Worn or damaged brake	Repair or replace brake

IMPORTANT!

SAFETY PRECAUTIONS AND PROCEDURES PRESENTED IN THIS MANUAL CANNOT ANTICIPATE ALL POSSIBLE CIRCUMSTANCES AND SITUATIONS YOU MAY ENCOUNTER. IT IS ALWAYS ESSENTIAL TO USE YOUR COMMON SENSE AND MAXIMUM SAFETY.

WE WISH YOU SUCCESSFUL USE OF

HUSARWINCH

PRODUCTS!

BST 2000lbs	Technical specifications
Pull capacity(single line)	2000lbs / 907 kgs
Motor 12V	0.9 hp
Controls	Wired remote control
Gear ratio	153:1
Brake	Automatic
Rope	15m Ø 4mm
Net weight	6,0kg
Fairlead	4-ways rollers fairlead
Dimensions	(L x W x H) 285 x 105 x 105mm

Line speed and motor current (first layer)

Line pull	Lbs	0	500	1000	1500	2000
	Kgs	0	227	454	680	907
Line speed	M/min	3,2	2,8	2,3	1,6	0,6
Motor current	Amps	12	30	60	90	120

Line pull and cable capacity

Layer of cable		1	2	3	4	5
Rated line pull per layer	Lbs	2000	1630	1380	1190	1050
	Kgs	906	740	620	540	470
Cable capacity per layer	M	2	4,3	7,2	10,6	15

BST 2500lbs	Technical specifications
Pull capacity(single line)	2500lbs / 1134 kg
Motor 12V	0,9 KM
Controls	Pilot przewodowy
Gear ratio	153:1
Brake	Automatic
Rope	10m
Fairlead	4 rolki
Net weight	6,5kg
Dimensions	(Dł x Szer x Wys) 300 x 105 x 105mm

Line pull and cable capacity

Line pull	Lbs	0	1000	2000	2500	-
	Kg	0	454	907	1134	-
Line speed	m/min	2,8	2	1	0,8	-
Motor current	Amper	12	60	120	140	-

Line pull and cable capacity

Layer of cable		1	2	3	4	5
Rated line pull per layer	Lbs	2500	1630	1380	1190	1050
	Kg	1132	740	620	540	470
Cable capacity per layer	m	1,5	3,5	5,9	8,7	10

BST 3000lbs	Technical specifications
Pull capacity(single line)	3000 lb (1361 kg)
Motor 12V	0,9kw / 1,2hp
Controls	Wired remote contro
Gear ratio	153:1
Brake	Automatic
Rope	10m Ø 5,5mm
Fairlead	4-ways rollers fairlead
Net weight	10kg
Dimensions	(L x W x H) 300mm x102mm x106 mm

Line speed and motor current (first layer)

Line pull	Lbs	0	500	1000	2000	3000
	Kgs	0	227	454	907	1361
Line speed	M/min	3,2	2,8	2,3	1,8	1,3
Motor current	Amps	12	30	60	90	120

Line pull and cable capacity

Layer of cable		1	2	3	4	5
Rated line pull per layer	Lbs	3000	2370	1960	1670	1460
	Kgs	1360	1052	858	720	620
Cable capacity per layer	M	1,5	3,5	5,9	8,7	10

BST S 3000lbs	Technical specifications
Pull capacity(single line)	3000lbs / 1361 kgs
Motor 12V	1.5 KM / 1,0 kw
Controls	Wired / wireless remote control
Gear ratio	138:1
Brake	automatic
Rope	12m x Ø 4.8mm
Fairlead	4-ways rollers fairlead
Rozstaw śrub montażowych	124mm x 76mm
Net weight	7,5kg
Dimensions	(L x W x H) 334 X 114 X 120mm

Line speed and motor current (first layer)

Line pull	Lbs	0	1000	2000	3000
	Kgs	0	454	907	1360
Line speed	M/min	7,5	4,5	3,2	2,1
Motor current	Amps	15	75	120	175

Line pull and cable capacity

Layer of cable		1	2	3	4
Rated line pull per layer	Lbs	3000	2520	2170	1870
	Kgs	1360	1140	985	849
Cable capacity per layer	M	2,2	4,8	7,9	12

BST S 3500lbs	Technical specifications
Pull capacity(single line)	3500lbs / 1587 kgs
Motor 12V	1.5 KM / 1,0 kw
Controls	Wired / wireless remote control
Gear ratio	198:1
Brake	Automstic
Rope	12m Ø 5,5 mm
Fairlead	4-ways rollers fairlead
Net weight	8kg
Mounting bolt pattern	124mm x 76mm
Dimensions	(L x W x H) 334mm × 114mm × 120mm

Line speed and motor current (first layer)

Line pull	Lbs	0	1000	2000	3000	3500
	Kgs	0	454	907	1360	1589
Line speed	M/min	4,9	3,2	2,8	2,2	1,8
Motor current	Amps	15	70	105	135	150

Line pull and cable capacity

Layer of cable		1	2	3	4
Rated line pull per layer	Lbs	3500	2870	2430	2100
	Kgs	1598	1300	1100	950
Cable capacity per layer	M	2,1	4,6	7,6	12

BST S 4500lbs	Technical specifications
Pull capacity(single line)	4500lbs / 2041 kgs
Motor 12V	18 KM / 1,3 kw
Controls	Wired / wireless remote control
Gear ratio	198.:1
Brake	automatic
Rope	12 m Ø 6,3 mm
Fairlead	4-ways rollers fairlead
Net weight	11 kg
Mounting bolt pattern	165mm x 76mm
Dimensions	(L x W x H) 391mm × 114mm × 120mm

Line speed and motor current (first layer)

Line pull	Lbs	0	1000	2000	3000	4500
	Kgs	0	454	907	1360	2041
Line speed	M/min	4,9	3,2	2,8	2,2	1,2
Motor current	Amps	17	70	105	135	210

Line pull and cable capacity

Layer of cable		1	2	3	4
Rated line pull per layer	Lbs	4500	3841	3310	2907
	Kgs	2041	1742	1501	1319
Cable capacity per layer	M	2	4,3	7,2	12

BST 5500lbs	Technical specifications
Pull capacity (single line)	5500lbs / 2495 kg
Motor 12V	2.5 KM / 3,4 kW
Controls	Wired / wireless remote control
Gear	166:01:00
Brake	automatic
Rope	14,5 m Ø 6 mm
Fairlead	4-ways rollers fairlead
Net weight	15,5kg
Mounting bolt pattern	168mm x 76,2mm
Dimensions	(Dł x Szer x Wys)408mmx125mmx123mm

Prędkość linii i prąd silnika (pierwsza warstwa)

Obciążenie liny	Lbs	0	2000	3000	4500	5500
	Kg	0	1523	1750	2057	2495
Prędkość liny	m/min	3.9	2.6	2.1	1.4	1.1
Pobór prądu	Amper	28	120	160	220	280

Siła uciągu w zależności od warstwy liny

Warsta liny		1	2	3	4
Uciąg liny	Lbs	5500	6640	5600	4800
	Kg	2495	3012	1750	1523
Ilość liny na bębnie	m	3.7	8	12.8	14,5

BST 8500lbs	Specyfikacja techniczna
Pull capacity(single line)	8500lbs / 3856 kgs
Motor 12V	5.5 hp
Controls	Wired / wireless remote control
Gear	3-stage planetary
Gear ratio	218:1
Brake	automatic
Rope	24m Ø 7,8mm
Fairlead	4-ways rollers fairlead
Net weight	32 kg
Mounting bolt pattern	166mm x 114,3mm
Dimensions	(L x W x H) 430 X 160 X 218mm

Line speed and motor current (first layer)

Line pull	Lbs	0	2000	4000	6000	8500
	Kgs	0	907	1814	2722	3855
Line speed	M/min	7,8	4,88	3,63	2,98	2,44
Motor current	Amps	80	130	180	230	290

Line pull and cable capacity

Layer of cable		1	2	3	4
Rated line pull per layer	Lbs	8500	6640	5600	4800
	Kgs	3855	3012	2540	2177
Cable capacity per layer	M	6	13,2	22	28

BST 10000lbs	Technical specifications
Pull capacity(single line)	10000lbs / 4536 kgs
Motor 12V	5.5 hp / 4,0 kw
Controls	Wired / wireless remote control
Gear	3-stage planetary
Gear ratio	218:1
Brake	automatic
Rope	28m x Ø 8,5 mm
Fairlead	4-ways rollers fairlead
Net weight	35 kg
Mounting bolt pattern	254mm x 114,3mm
Dimensions	(L x W x H) 546mm x 160mm x 218mm

Line speed and motor current (first layer)

Line pull	Lbs	0	2000	6000	8000	10000
	Kgs	0	907	2722	3629	4536
Line speed	M/min	6,8	4,88	3,98	2,44	1,8
Motor current	Amps	80	130	230	290	350

Line pull and cable capacity

Layer of cable		1	2	3	4
Rated line pull per layer	Lbs	10000	8800	7800	6600
	Kgs	4535	3990	3538	2994
Cable capacity per layer	M	6	13,2	22	28

BST 12000lbs	Technical specifications
Pull capacity(single line)	12000lbs / 5443 kgs
Motor 12V	6.0 KM / 4,4 kw
Controls	Wired / wireless remote control
Gear	3-stage planetary
Gear ratio	265:1
Brake	automatic
Rope	25m x Ø 9,5 mm
Fairlead	4-ways rollers fairlead
Net weight	38 kg
Mounting bolt pattern	254mm x 114,3mm
Dimensions	(L x W x H) 546mm x 160mm x 218mm

Line speed and motor current (first layer)

Line pull	Lbs	0	4000	6000	10000	12000
	Kgs	0	1814	2722	4536	5443
Line speed	M/min 12V	6,8	3,8	3	2,1	1,7
	M/min 24V	10	7	5,5	3,2	2,7
Motor current	Amps 12V	80	170	210	310	360
	Amps 24V	45	70	95	185	240

Line pull and cable capacity

Layer of cable		1	2	3	4
Rated line pull per layer	Lbs	12000	9900	8300	7000
	Kgs	5443	4490	3765	3175
Cable capacity per layer	M	6	13	22	25

BST S 12000lbs	Technical specifications
Pull capacity(single line)	12000lbs / 5443 kg
Motor 12V	6.0 KM / 4,4 Kw
Controls	Wired / wireless remote control
Gear	3-stage planetary
Gear ratio	265:1
Brake	Automatic
Rope	25m x Ø 9,5 mm
Fairlead	4-ways rollers fairlead
Net weight	39 kg
Mounting bolt pattern	254mm x 114,3mm
Dimensions	(L x W x H) 545mm x 160mm x 195mm

Line speed and motor current (first layer)

Line pull	Lbs	0	4000	6000	10000	12000
	Kg	0	1814	2722	4536	5443
Line speed	M/min 12V	6,8	3,8	3	2,1	1,7
Motor current	Amper 12V	80	170	210	310	360

Line pull and cable capacity

Layer of cable		1	2	3	4
Rated line pull per layer	Lbs	12000	9900	8300	7000
	Kg	5443	4490	3765	3175
Cable capacity per layer	M	6	13	22	25

Reted line pull	12000Lbs / 5443kgs
Motor 12V	Two Series Wound Motors with single 7hp/3.2kw
Gear Train	3 Stage Planetary Gear & Transmission Gear
Gear ratio	138:1
Clutch	Air clutch
Braking action	Automatic in the drum
Fairlead	Aluminum hawse
Synthetic Rope	50m Ø 11mm
Drum Size	64mm x 299mm
Mounting Bolt Ptttern	330mm x 114.3mm
N.W	69kgs
Packing	590 mm×300 mm×490 mm

Line speed and motor current (first layer)

Line pull	Lbs	0	6000	9000	12000
	Kgs	0	2727	4090	5443
Line speed	MPM	17	6	5.2	4.6
Motor current	Amps	138	440	550	640

BST V 12000Lbs	
Rated line pull:	12000 Lbs 5443kes
Motor:	6.6 hp /4.9kw.12V DC
Gear Train:	3 stage planetary
Gear ratio:	216:1
Clutch:	Sliding Ring gear
Braking action:	Automatic in the drum
Fairlead:	Aluminum hawse fairlead
wire rope:	10 mm ×26m
Drum size:	63mm×224mm
Dimensions:	563mm×162mm×196mm
Mounting bolt pattern:	10"×4.5"(254mm×114.3mm)
Battery	Recommended 650 CCA minimum for winching 25 square mm, 1.83m
N.W:	30kes
Packing:	610mm X 360mm X 260m

Line Line speed and motor current (first layer) and motor current (first layer)						
Line pull	LBS	0	4000	6000	9500	12000
	Kes	0	1814	2722	4309	5443
Line speed	MPM	10	4,6	4	3,2	2,8
Motor current	Amps	70	210	260	380	420

Line pull and cable Capacity					
Layer of cable		1	2	3	4
Rated line pull per layer	Lbs	12000	9919	8221	7019
	Kes	5443	4499	3729	3183
Cable capacity per layer	M	4,8	10,8	18,1	26

BST 13000lbs	Technical specifications
Pull capacity(single line)	13000lbs / 5897 kgs
Motor 12V	6.5 KM / 4,5 kw
Controls	Wired / wireless remote control
Gear	3-stage planetary
Gear ratio	265:1
Brake	Automatyczny
Rope	25m x Ø 10 mm
Fairlead	4-ways rollers fairlead
Net weight	38 kg
Mounting bolt pattern	254mm x 114,3mm
Dimensions	(L x W x H) 546mm x 160mm x 218mm

Line speed and motor current (first layer)

Line pull	Lbs	0	4000	6000	10000	13000
	Kgs	0	1814	2722	4536	5897
Line speed	M/min 12V	6,8	3,8	3	2,1	1,7
	M/min 24V	10	7	5,5	3,2	2,7
Motor current	Amps 12V	80	170	210	310	380
	Amps 24V	45	70	95	185	250

Line pull and cable capacity

Layer of cable		1	2	3	4
Rated line pull per layer	Lbs	13000	9900	8300	7000
	Kgs	5897	4490	3765	3175
Cable capacity per layer	M	6	13	22	25

BST S 13000lbs	Technical specifications
Pull capacity(single line)	13000lbs / 5897 kes
Motor 12V / 24V	6.5 KM / 4.5 Kw 8.5KM/6.4kW
Controls	Wired / wireless remote control
Gear	3-stage planetary
Gear ratio	265:1
Brake	Automatic
Rope	15m x Ø 10 mm
Fairlead	4-wavs rollers fairlead
Net weight	32 kg
Mounting bolt pattern	254mm x 114.3mm
Dimensions	(L x W x H) 546mm x 160mm x 218mm

Line speed and motor current (first laver)					
Line pull	Lbs	0	5000	8000	13000
	Kes	0	2268	3629	5897
Line speed	M/min 12V	6.8	5.3	2.55	1.7
	M/min 24V	10	6.25	4.35	2.7
Motor current	Amps 12V	80	190	260	380
	Amps 24V	45	82.5	140	250

Line pull and cable capacity				
Laver of cable		1	2	3
Rated line pull per laver	Lbs	13000	8000	5000
	Kes	5897	3629	2268
Cable capacity per laver	M	2	8	15



DECLARATION OF CONFORMITY

ENG/01/05/2020/CE

(report No.)

1. Product manufacturer: KWELLA Sp. z o. o.
ul. Mickiewicza 36
32-626 Jawiszowice
2. Trademark **HUSAR WINCH**
3. Description of equipment **Electric Winch**
4. Model and/or serial number: BST 2000 lbs, BST 2500 lbs, BST 3000 lbs, BSTS 3000lbs
BST S 3500 lbs, BSTS 4500 lbs, BST S 5500 lbs, BST 8500 lbs, BST 10000 lbs,
BST 12000 lbs, BST S 12000 lbs, BST V 12000 lbs, BST S 12000 DS lbs, BST 13000 lbs,
BST S 13000 lbs, BST S 14000 lbs, BST S 15000 lbs, BST S 17000lbs,
BST S 18000 lbs, BST S 20000 lbs, BST 22000 lbs
Hydraulic Winch
BST H 12000 lbs, BST H 15000 lbs, BST H 18000 lbs,
BST H 20000 lbs, BST H 080 lbs, BST H 35000 lbs, BST H 45000 lbs
5. Purpose & scope of the product application : **The machines designed to:**
-pull damaged vehicles
- move of drag goods
- remover pull OFF Road vehicles
(In accordance with the reference document)
6. List of standards used & reference documentation: **The Machinery Directive MD**
2006/42/WE
-PN-EN 14492-2+A1:2010/AC:2014-7
— PN-EN ISO 12100:2012

Electromagnetic compatibility directive: EMC 2014/30/UE

(In accordance with the reference document)

I declare with full responsibility that the products referred to in item 3 and 4 are compliant with the reference documents mentioned in item 6.

25/05/2020

(date of issue)



(Name&signature of authorized person)



DECLARATION OF CONFORMITY

ENG/EN/01/05/2020/CE

(report No.)

1. Product manufacturer:

KWELLA Sp. z o. o.

ul. Mickiewicza 36

32-626 Jawiszowice

2. Trademark

HUSAR WINCH

3. Description of equipment

ElectricWinch

4. Model and/or serial number:

BST-EN 10000 lbs,

BST-EN 12000 lbs, BST-EN 14000 lbs

Hydraulic Winch

BST H 12000 lbs, BST H 15000 lbs, BST H 18000 lbs,

BSTH 20000 lbs, BST H 080, BST H 35000lbs, BST H 45000lbs

5. Purpose & scope of the product application :

The machines designed to:

-pull damaged vehicles

- move of drag goods

- remover pull OFF Road vehicles

(In accordance with the reference document)

6. List of standards used & reference documentation:

The Machinery Directive MD

2006/42/WE

-PN-EN 14492-2+A1:2010/AC:2014-7

PN-EN ISO 12100:2012

Electromagnetic compatibility directive: EMC 2014/30/UE

(In accordance with the reference document)

I declare with full responsibility that the products referred to in item 3 and 4 are compliant with the

25/05/2020

(date of issue)



(Name&signature of authorized person)

DEAR CUSTOMER,

Thank you for purchasing HUSAR WINCH. In case of technical problems, please contact the service.

WARRANTY CONDITIONS

1. The warranty covers winches with a valid warranty documents. The warranty is valid together with the proof of purchase.
2. The warranty is granted for the period of 24 months from the winch delivery date. The delivery date is indicated on the warranty.
3. The guarantor undertakes to repair the factory defects of the winch found during the warranty period.
4. The warranty does not cover the winch defects occurring as a result of:

Repairs performed otherwise than by the guarantor, failure to comply with the principles of proper installation and operation described in the operation manual, storing the winch in improper conditions. neglect, lack of supervision, misuse, failure to follow winch handling principles, overloading the winch, random phenomena, such as: fire, electric discharge, flooding, operation of chemicals and force majeure circumstances and events.
5. The warranty does not cover mechanical operation defects such as:

enclosure damage, motor, gear and drum damage, caused by overloading the winch. The parameters winch, if exceeded, shall constitute winch overloading are specified in detail in the operation manual for the specified winch type.
6. The warranty does not cover enclosure elements and accessories which are subject to normal wear and tear during operation, such as: Scratching, persistent dirt, wearing the inscriptions, etc.
7. The winch rope, both steel rope and synthetic rope, is not covered by the warranty.
8. The warranty does not cover winches which the non-operational due to failure to assure proper maintenance.
9. The basis for considering the warranty claim is supplying the winch together with a valid warranty certificate, proof of purchase and complaint form, which should describe the defect and the circumstances in which it occurred as well as the type of vehicle in which the winch installed.
10. Contact the guarantor concerning the winch delivery at the specified address of the services, the guarantor shall cover the cost of transportation, as long as the winch is shipped through the courier indicated by the guarantor.
11. A defect reported during the warranty period shall be repaired by the guarantor at the guarantor's cost within 14 working days. The period shall commence on the first working day after the date of delivery to the service.

12. If the repair requires spare parts to be imported from abroad, the repair period may be extended to 60 days, to which the customer consents by using the service.
13. the customer is entitled to replacement of the winch into the new one if the guarantor finds the repair to be impossible. The winch shall be replaced with a new one, defect-free within not more than 30 days. If, in special cases (e.g. No such product non offer), the winch may not be replaced with the same type, the guarantor, on agreement with the customer, shall replace the winch into the winch of another type, with possibly the closest technical parameters. Such procedure shall be considered fulfilling the guarantor's obligations.
14. The warranty is extended by the period of the warranty service.
15. If the complaint turns out to be unfounded, the guarantor shall charge the customer with the cost of the warranty procedures and transport costs.
16. The guarantor is not liable for the damages resulting from incorrect winch operation. The guarantor shall not be responsible for additional costs incurred by the customer, resulting from damaging the winch.
17. The warranty rights do not incorporate the customer's claim for reimbursement of profits lost in connection with the winch defect.
18. If the customer does not accept the warranty conditions, they are entitled to return the winch to the seller at its own expense within 5 working days from the date of purchase. In this case, the winch may not show any signs of use.
19. In disputable matters, not regulated by this warranty, applicable regulations of the

MODEL	NUMBER	DATE